

**This electronic collection of documents is provided
for the convenience of the user
and is Not a Certified Document –**

**The documents contained herein were originally issued
and sealed by the individuals whose names and license
numbers appear on each page, on the dates appearing
with their signature on that page.**

**This file or an individual page
shall not be considered a certified document.**



STATE OF NORTH CAROLINA
DIVISION OF HIGHWAYS

TRANSPORTATION MANAGEMENT PLAN

WARREN COUNTY
(BRIDGE NO. 920139)

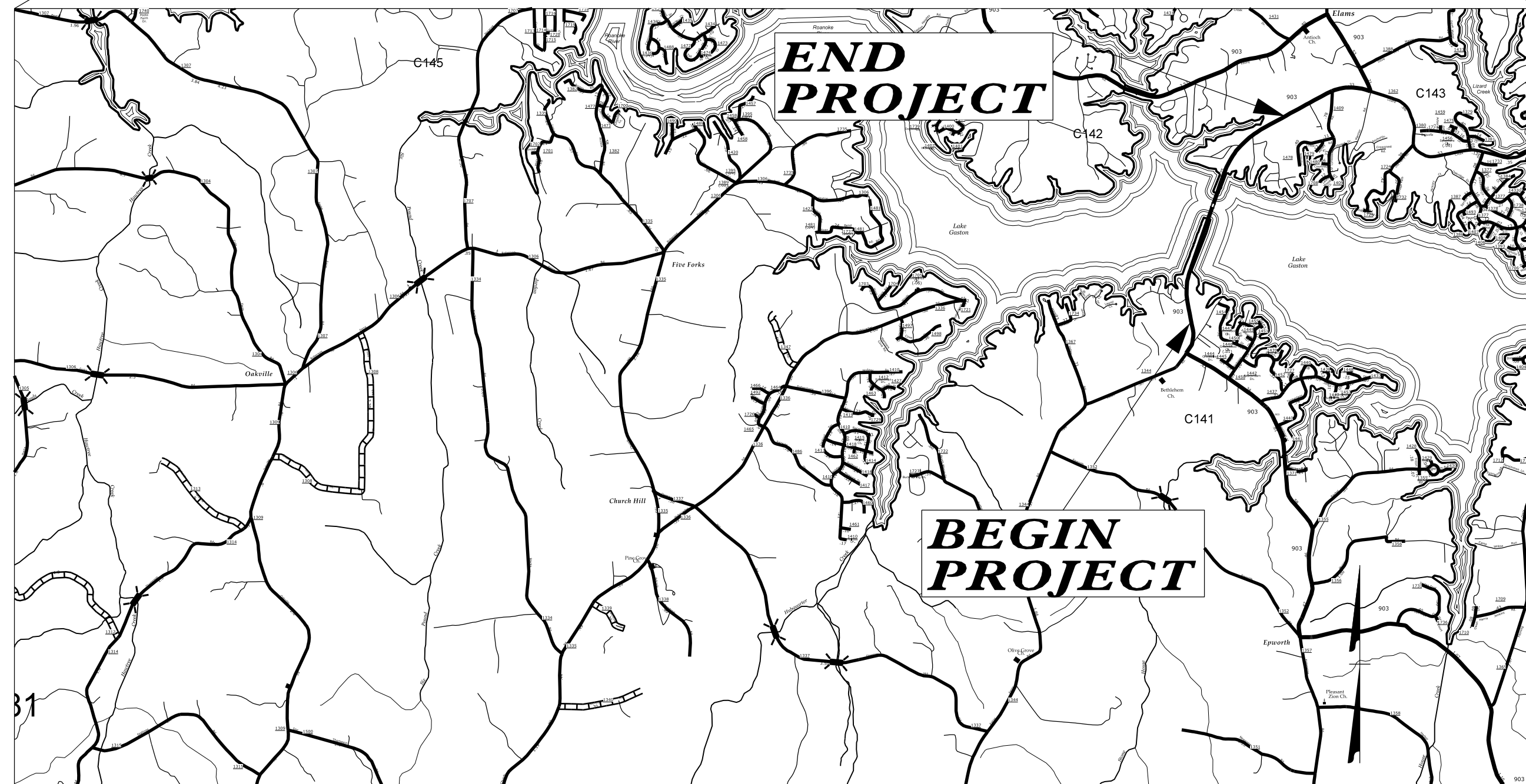
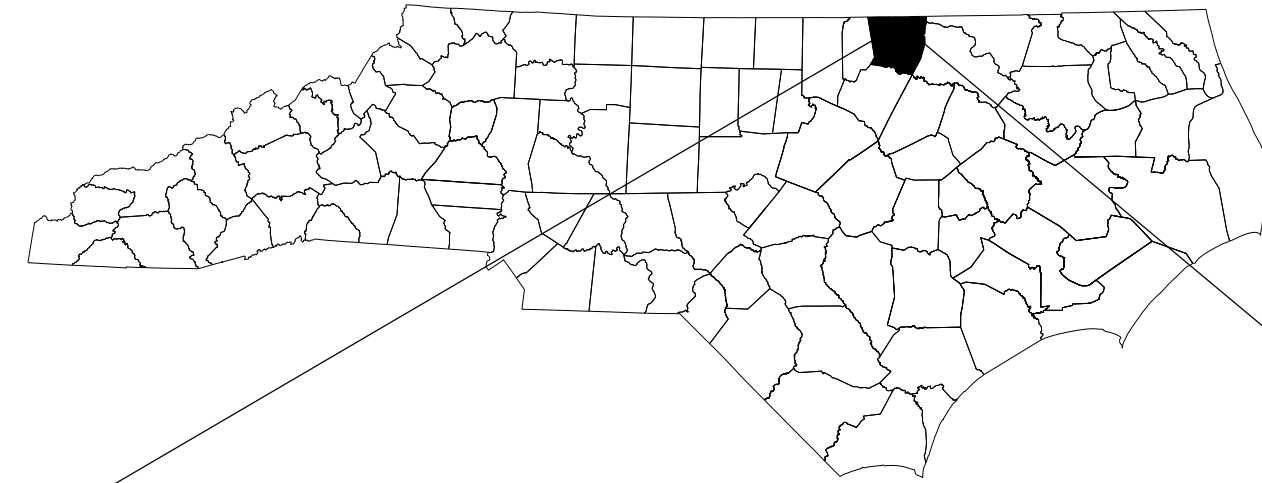

PROJECT VICINITY MAP

INDEX OF SHEETS	
<u>SHEET NO.</u>	<u>TITLE</u>
TMP-1	TITLE SHEET, VICINITY MAP, AND INDEX OF SHEETS
TMP-1A	LIST OF APPLICABLE ROADWAY STANDARD DRAWINGS, AND LEGEND
TMP-1B	TRANSPORTATION OPERATIONS PLAN: (MANAGEMENT STRATEGIES, GENERAL NOTES, AND LOCAL NOTES)
TMP-2	WATERWAY DETAIL
TMP-3	TEMPORARY TRAFFIC CONTROL PHASING
TMP-4	TEMPORARY TRAFFIC CONTROL PHASE I DETAIL
TMP-5	TEMPORARY TRAFFIC CONTROL PHASE II DETAIL

SHEET NO.
TMP-1

15BPR.2

WBS PROJECT:

**DOCUMENT NOT CONSIDERED FINAL
UNLESS ALL SIGNATURES COMPLETED**

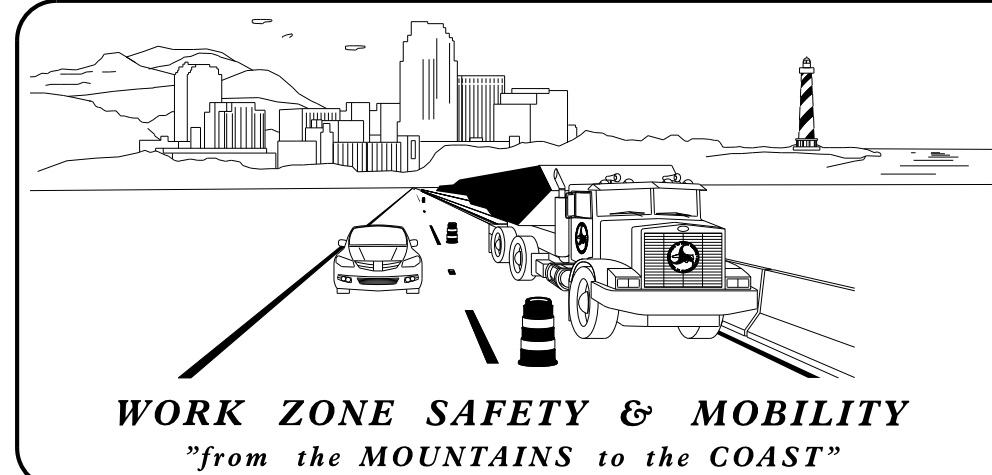

PLANS PREPARED BY:

J.S. BOURNE, P.E.

B,W, JOHNSON, P.E.

NCDOT CONTACTS:

J.S. KITE, P.E.
PROJECT ENGINEER

M.V. SPRINGER, P.E.
PROJECT DESIGN ENGINEER

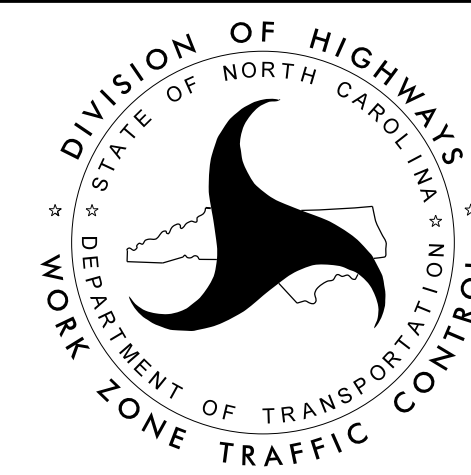

Prepared In the Office of:



NC FIRM LICENSE No: P-0339
504 Meadowlands Drive
Hillsborough, NC 27278
(919) 732-3883
(919) 732-6676 (FAX)

APPROVED: J. Stuart Bourne
307650CT012480

DATE: 2/2/2018

SEAL

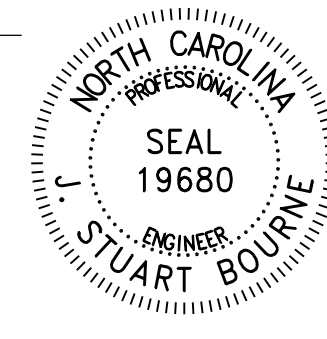







ROADWAY STANDARD DRAWINGS

THE FOLLOWING ROADWAY STANDARDS AS SHOWN IN "ROADWAY STANDARD DRAWINGS" - N.C. DEPARTMENT OF TRANSPORTATION - RALEIGH, N.C., DATED JANUARY 2018 ARE APPLICABLE TO THIS PROJECT AND BY REFERENCE HEREBY ARE CONSIDERED A PART OF THESE PLANS:

STD. NO.	TITLE
1101.01	WORK ZONE ADVANCE WARNING SIGNS
1101.02	TEMPORARY LANE CLOSURES
1101.03	TEMPORARY ROAD CLOSURES
1101.11	TRAFFIC CONTROL DESIGN TABLES
1110.01	STATIONARY WORK ZONE SIGNS
1110.02	PORTABLE WORK ZONE SIGNS
1130.01	DRUM
1135.01	CONES
1145.01	BARRICADES
1150.01	FLAGGING DEVICES
1165.01	WORK VEHICLE LIGHTING SYSTEMS AND TMA DELINEATION
1180.01	SKINNY-DRUM
1205.01	PAVEMENT MARKINGS - LINE TYPES AND OFFSETS
1205.02	PAVEMENT MARKINGS - TWO-LANE AND MULTI-LANE ROADWAYS
1205.12	PAVEMENT MARKINGS - BRIDGES
1250.01	RAISED PAVEMENT MARKERS - INSTALLATION SPACING
1251.01	RAISED PAVEMENT MARKERS - PERMANENT AND TEMPORARY

LEGEND

GENERAL

-  DIRECTION OF TRAFFIC FLOW
-  DIRECTION OF PEDESTRIAN TRAFFIC FLOW
-  EXIST. PVMT.
-  NORTH ARROW
-  PROPOSED PVMT.
-  TEMP. SHORING (LOCATION PURPOSES ONLY)



 WORK AREA

 REMOVAL

 USER DEFINED (IF NEEDED)

 USER DEFINED (IF NEEDED)



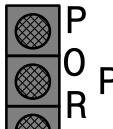







SIGNALS

-  EXISTING
-  PROPOSED
-  PORTABLE

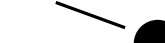
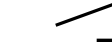

PAVEMENT MARKINGS

-  EXISTING LINES
-  TEMPORARY LINES



TRAFFIC CONTROL DEVICES

-  BARRICADE (TYPE III)
-  CONE
-  DRUM
-  SKINNY DRUM
-  TUBULAR MARKER
-  TEMPORARY CRASH CUSHION
-  FLASHING ARROW BOARD
-  FLAGGER
-  LAW ENFORCEMENT
-  TRUCK MOUNTED ATTENUATOR (TMA)
-  CHANGEABLE MESSAGE SIGN

TEMPORARY SIGNING

-  PORTABLE SIGN
-  STATIONARY SIGN
-  STATIONARY OR PORTABLE SIGN

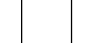
PAVEMENT MARKERS

-  CRYSTAL/CRYSTAL
-  CRYSTAL/RED
-  YELLOW/YELLOW

PAVEMENT MARKING SYMBOLS

-  PAVEMENT MARKING SYMBOLS

TEMPORARY PAVEMENT MARKINGS

COLD APPLIED PLASTIC (4") TYPE 4 REMOVABLE TAPE

SYMBOL	DESCRIPTION
CA	WHITE EDGELINE
CI	YELLOW DOUBLE CENTER

COLD APPLIED PLASTIC (24") TYPE 4 REMOVABLE TAPE

SYMBOL	DESCRIPTION
C2	WHITE STOPBAR

FINAL PAVEMENT MARKING

COLD APPLIED PLASTIC (4") TYPE 3 PERMANENT WET REFLECTIVE

SYMBOL	DESCRIPTION
CA	WHITE EDGELINE
CI	YELLOW DOUBLE CENTER

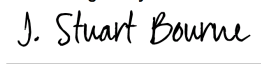
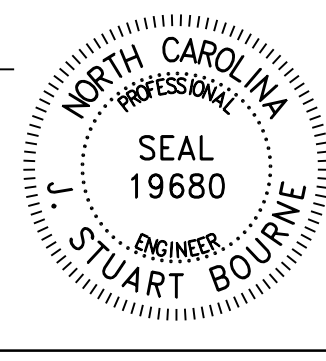
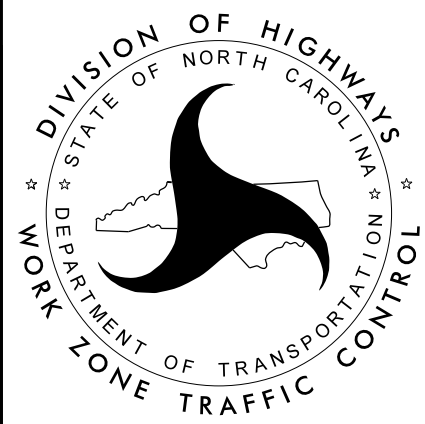
APPROVED: 			ROADWAY STANDARD DRAWINGS & LEGEND
DATE: 2/2/2018			
DOCUMENT NOT CONSIDERED FINAL UNLESS ALL SIGNATURES COMPLETED			

GENERAL NOTES

CHANGES MAY BE REQUIRED WHEN PHYSICAL DIMENSIONS IN THE DETAIL DRAWINGS, STANDARD DETAILS, AND ROADWAY DETAILS ARE NOT ATTAINABLE TO MEET FIELD CONDITIONS OR RESULT IN DUPLICATE OR UNDESIRED OVERLAPPING OF DEVICES. MODIFICATION MAY INCLUDE: MOVING, SUPPLEMENTING, COVERING, OR REMOVAL OF DEVICES AS DIRECTED BY THE ENGINEER.

THE FOLLOWING GENERAL NOTES APPLY AT ALL TIMES FOR THE DURATION OF THE CONSTRUCTION PROJECT EXCEPT WHEN OTHERWISE NOTED IN THE PLAN OR AS DIRECTED BY THE ENGINEER

TIME RESTRICTIONS

- A) DO NOT CLOSE OR NARROW TRAVEL LANES ON NC 903 BETWEEN THE HOURS OF 5:00 AM TO 11:00 PM BEGINING AT 5:00 AM THE THURSDAY BEFORE MEMORIAL DAY TO 5:00 AM THE TUESDAY AFTER LABOR DAY.
- B) DO NOT CLOSE OR NARROW TRAVEL LANES DURING HOLIDAYS AND SPECIAL EVENTS AS FOLLOWS:

ROAD NAME:

NC 903

HOLIDAY

1. FOR ANY UNEXPECTED OCCURENCE THAT CREATES UNUSUALLY HIGH TRAFFIC VOLUMES, AS DIRECTED BY THE ENGINEER.
2. FOR NEW YEAR'S, BETWEEN THE HOURS OF 3:00 PM DECEMBER 31st TO 7:00 AM JANUARY 2nd. IF NEW YEAR'S DAY IS ON A FRIDAY, SATURDAY, SUNDAY OR MONDAY THEN UNTIL 7:00 AM THE FOLLOWING TUESDAY.
3. FOR EASTER, BETWEEN THE HOURS OF 3:00 PM THURSDAY AND 7:00 AM MONDAY
4. FOR MEMORIAL DAY SEE GENERAL NOTE A
5. FOR INDEPENDENCE DAY SEE GENERAL NOTE A
6. FOR LABOR DAY SEE GENERAL NOTE A
7. FOR THANKSGIVING DAY, BETWEEN THE HOURS OF 3:00 PM TUESDAY TO 7:00 AM MONDAY.
8. FOR CHRISTMAS, BETWEEN THE HOURS OF 3:00 PM THE FRIDAY BEFORE THE WEEK OF CHRISTMAS DAY AND 7:00 AM THE FOLLOWING TUESDAY AFTER THE WEEK OF CHRISTMAS.

- C) DO NOT CLOSE ROADS AS FOLLOWS:

ROAD NAME	DAY AND TIME RESTRICTIONS
ALL ROADS	ANYTIME

LANE AND SHOULDER CLOSURE REQUIREMENTS

- D) REMOVE LANE CLOSURE DEVICES FROM THE LANE WHEN WORK IS NOT BEING PERFORMED BEHIND THE LANE CLOSURE OR WHEN A LANE CLOSURE IS NO LONGER NEEDED OR AS DIRECTED BY THE ENGINEER.
- E) WHEN PERSONNEL AND/OR EQUIPMENT ARE WORKING WITHIN 15 FT OF AN OPEN TRAVEL LANE, CLOSE THE NEAREST OPEN SHOULDER USING ROADWAY STANDARD DRAWING NO. 1101.04 UNLESS THE WORK AREA IS PROTECTED BY BARRIER OR GUARDRAIL OR A LANE CLOSURE IS INSTALLED.
- F) WHEN PERSONNEL AND/OR EQUIPMENT ARE WORKING ON THE SHOULDER WITHIN 5 FT ADJACENT TO AN UNDIVIDED FACILITY AND WITHIN 5 FT OF AN OPEN TRAVEL LANE, CLOSE THE NEAREST TRAVEL LANE USING ROADWAY STANDARD DRAWING NO. 1101.02 UNLESS THE WORK AREA IS PROTECTED BY BARRIER OR GUARDRAIL.

WHEN PERSONNEL AND/OR EQUIPMENT ARE WORKING ON THE SHOULDER ADJACENT TO A DIVIDED FACILITY AND WITHIN 10 FT OF AN OPEN TRAVEL LANE, CLOSE THE NEAREST OPEN TRAVEL LANE USING ROADWAY STANDARD DRAWING NO. 1101.02 UNLESS THE WORK AREA IS PROTECTED BY BARRIER OR GUARDRAIL.

- G) WHEN PERSONNEL AND/OR EQUIPMENT ARE WORKING WITHIN A LANE OF TRAVEL OF AN UNDIVIDED OR DIVIDED FACILITY, CLOSE THE LANE ACCORDING TO THE TRAFFIC CONTROL PLANS, ROADWAY STANDARD DRAWINGS, OR AS DIRECTED BY THE ENGINEER. CONDUCT THE WORK SO THAT ALL PERSONNEL AND/OR EQUIPMENT REMAIN WITHIN THE CLOSED TRAVEL LANE.

- H) DO NOT WORK SIMULTANEOUSLY WITHIN 15 FT ON BOTH SIDES OF AN OPEN TRAVEL WAY, RAMP, OR LOOP WITHIN THE SAME LOCATION UNLESS PROTECTED WITH GUARDRAIL OR BARRIER.

PAVEMENT EDGE DROP OFF REQUIREMENTS

- I) BACKFILL AT A 6:1 SLOPE UP TO THE EDGE AND ELEVATION OF EXISTING PAVEMENT IN AREAS ADJACENT TO AN OPENED TRAVEL LANE THAT HAS EDGE OF PAVEMENT DROP- OFF AS FOLLOWS:

BACKFILL DROP-OFFS THAT EXCEED 2 INCHES ON ROADWAYS WITH POSTED SPEED LIMITS OF 45 MPH.

BACKFILL DROP-OFFS THAT EXCEED 3 INCHES ON ROADWAYS WITH POSTED SPEED LIMITS OF 45 MPH.

BACKFILL WITH SUITABLE COMPACTED MATERIAL, AS APPROVED BY THE ENGINEER, AT NO EXPENSE TO THE DEPARTMENT.

TRAFFIC PATTERN ALTERATIONS

- J) NOTIFY THE ENGINEER TWENTY ONE (21) CALENDAR DAYS PRIOR TO ANY TRAFFIC PATTERN ALTERATION.

SIGNING

- K) INSTALL ADVANCE WORK ZONE WARNING SIGNS WHEN WORK IS WITHIN 40 FT FROM THE EDGE OF TRAVEL LANE AND NO MORE THAN THREE (3) DAYS PRIOR TO THE BEGINNING OF CONSTRUCTION.

- L) ENSURE ALL NECESSARY SIGNING IS IN PLACE PRIOR TO ALTERING ANY TRAFFIC PATTERN

- M) INSTALL BLACK ON ORANGE "DIP" SIGNS (W8-2) AND /OR "BUMP" SIGNS (W8-1) 350 FT IN ADVANCE OF THE UNEVEN AREA, OR AS DIRECTED BY THE ENGINEER.

TRAFFIC CONTROL DEVICES

- N) WHEN LANE CLOSURES ARE NOT IN EFFECT SPACE CHANNELIZING DEVICES IN WORK AREAS NO GREATER IN FEET THAN TWICE THE POSTED SPEED LIMIT (MPH), EXCEPT, 10 FT ON- CENTER IN RADII, AND 3 FT OFF THE EDGE OF AN OPEN TRAVEL-WAY, REFER TO STANDARD SPECIFICATIONS FOR ROADS AND STRUCTURES SECTIONS 1130 (DRUMS), 1135 (CONES) AND 1180 (SKINNY DRUMS) FOR ADDITIONAL REQUIREMENTS.

- O) PLACE ADDITIONAL SETS OF THREE CHANNELIZING DEVICES (DRUMS, CONES OR SKINNY DRUMS) PERPENDICULAR TO THE EDGE OF TRAVEL-WAY ON 500 FT CENTERS WHEN UNOPENED LANES ARE CLOSED TO TRAFFIC.

PAVEMENT MARKINGS AND MARKERS

- P) INSTALL TEMPORARY PAVEMENT MARKING AND TEMPORARY PAVEMENT MARKERS ON INTERIM LAYERS OF PAVEMENT AS FOLLOWS:

ROAD NAME	MARKING	MARKER
NC 903	COLD APPLIED PLASTIC TYPE 4 REMOVABLE TAPE	TEMP RAISED

- Q) PLACE ONE APPLICATION OF PAINT FOR TEMPORARY TRAFFIC PATTERNS. PLACE A SECOND APPLICATION OF PAINT SIX (6) MONTHS AFTER THE INITIAL APPLICATION AND EVERY SIX MONTHS AS DIRECTED BY THE ENGINEER.

- R) TIE PROPOSED PAVEMENT MARKING LINES TO EXISTING PAVEMENT MARKING LINES.

- S) REMOVE/REPLACE ANY CONFLICTING/DAMAGED PAVEMENT MARKINGS AND MARKERS BY THE END OF EACH DAY'S OPERATION.

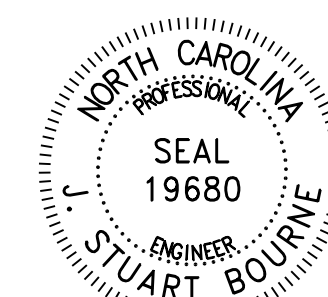
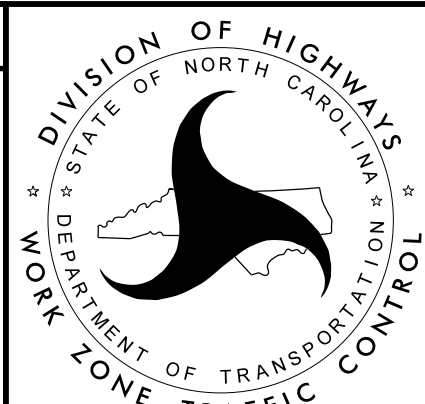
APPROVED: <u>J. Stuart Bourne</u> DATE: <u>2/8/2018</u> 		<h2 style="margin: 0;">GENERAL NOTES</h2>
--	---	---

GENERAL NOTES:

INFORMATION SHOWN IS SCHEMATIC ONLY. FINAL LOCATION AND NUMBER OF SIGNS AND BUOYS IS SUBJECT TO APPROVAL BY THE ENGINEER.

THE DETAILS SHOWN ARE FOR BIDDING PURPOSES ONLY. ALL MATERIALS AND LABOR NECESSARY TO INSTALL AND REMOVE.

SIGNS SHALL BE INCIDENTAL TO OTHER ITEMS.

THE CONTRACTOR IS RESPONSIBLE FOR BUOY MAINTENANCE THROUGHOUT CONSTRUCTION AND FOR DETERMINING ANTICIPATED WATER LEVELS DURING CONSTRUCTION. EACH SIGN AND BUOY SHALL BE ANCHORED TO BOTTOM OF LAKE.

SIGNS SHALL BE DOUBLE FACED.

EACH SIGN SHALL BE EQUIPPED WITH TWO (2) FLASHING LIGHT UNITS WITH AMBER LENS. FLASHING LIGHT UNITS SHALL BE FURNISHED AND MAINTAINED BY THE CONTRACTOR.

ALL LETTERING TO BE BLACK IN COLOR IN BLOCK FORM.

FOR OTHER INFORMATION AND LOCATION OF SIGNS AND BUOYS SEE SPECIAL PROVISIONS.

SCHEMATIC SHOWN IS FOR ONE NAVIGATIONAL SPAN. FOR WORK ON OTHER SPANS MOVE APPROPRIATE SIGNS WITH NO DIRECT PAY.

COLOR:
BACKGROUND - WHITE
LEGEND - BLACK
2" REFLECTIVE BAND AND SYMBOL - INTERNATIONAL ORANGE

FIXED STRUCTURES SUCH AS WORK PLATFORMS OR BARGES MUST BE LIT AT NIGHT.

LEGEND

- BOATS KEEP OUT (SIGN)
- BOATS KEEP OUT (BUOY)
- NO WAKE (BUOY)

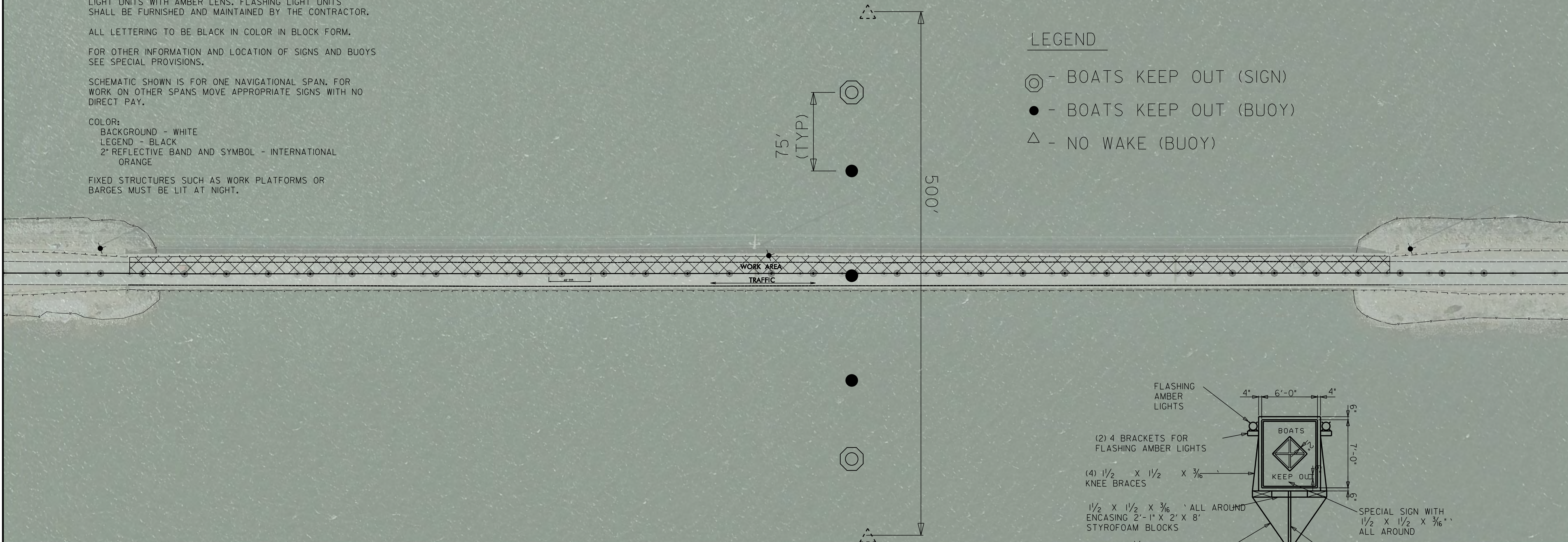

LAKE OR BODY OF WATER

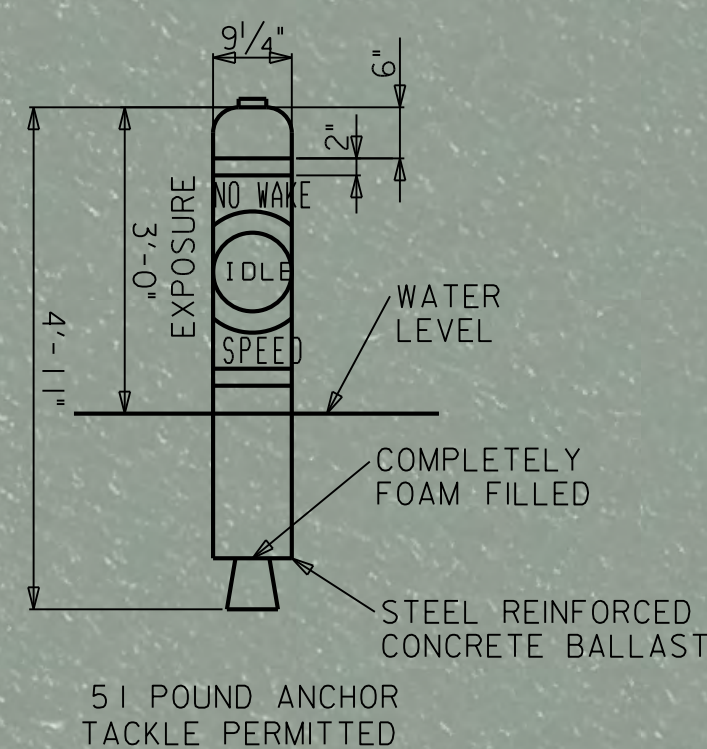

RESTRICTED AREA BUOY
(*NO WAKE*)
(6 REQUIRED - ROADWAY ITEM)

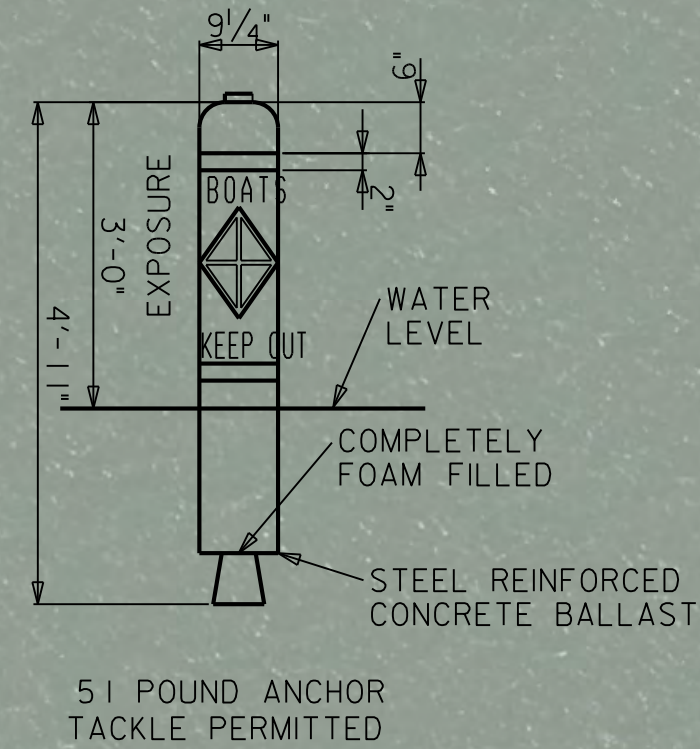

CONTROLLED AREA BUOY
(*BOATS KEEP OUT*)
(8 REQUIRED - ROADWAY ITEM)

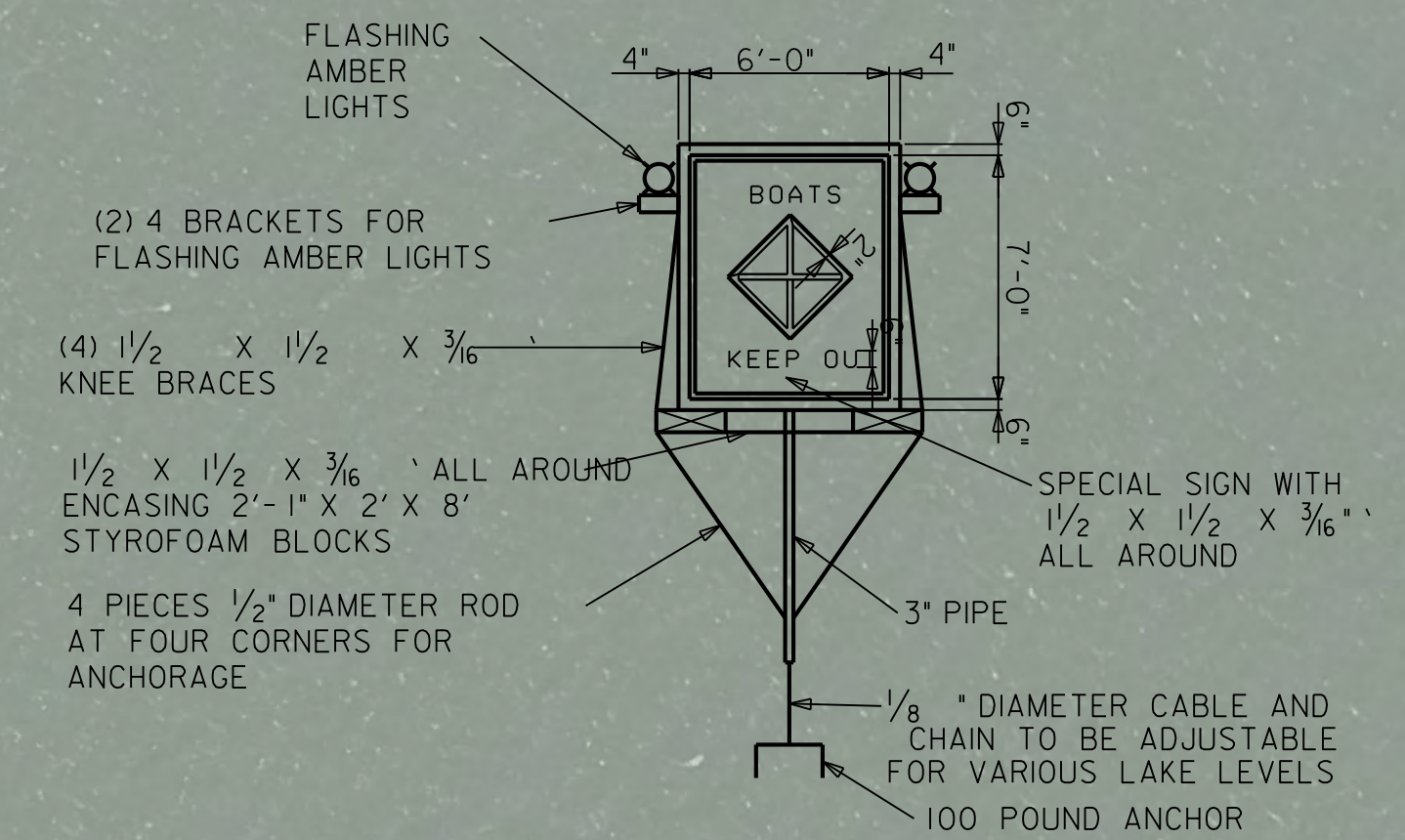

SPECIAL SIGN ASSEMBLY
(*BOATS KEEP OUT*)
(4 REQUIRED - ROADWAY ITEM)

02-FEB-2018 14:01
320195.LC.MPF.f4togn
spencer.merritt

APPROVED:

DATE: 2/2/2018

SEAL

**WATERWAY
DETAIL**

**DOCUMENT NOT CONSIDERED FINAL
UNLESS ALL SIGNATURES COMPLETED**

PHASING

NOTE: THE WORK IN AREA 1 (BRIDGE DECK REHABILITATION AND CAUSWAY SLOPE REPAIR) AND AREA 2 (PAINTING STRUCTURAL STEEL AND CONCRETE REPAIR OF THE SUBSTRUCTURE) ARE SEPARATE AND CAN BE PERFORMED SIMULTANEOUSLY AND / OR INDEPENDENTLY FROM THE WATER.

THE CONTRACTOR SHALL NOT CLOSE OR NARROW A LANE OF TRAFFIC ON NC 903 BETWEEN THE HOURS OF 5:00 AM TO 11:00 PM BEGINING AT 5:00 AM THE THURSDAY BEFORE MEMORIAL DAY TO 5:00 AM THE TUESDAY AFTER LABOR DAY. SEE GENERAL NOTE "A" AND INTERMEDIATE CONTRACT TIMES FOR LIQUIDATED DAMAGES.

AREA 1 PHASE I

STEP 1:
 USING ROADWAY STANDARD DRAWING 1101.02, SHEET 1 OF 14, CLOSE ONE LANE OF TRAFFIC AND INSTALL STATIONARY ADVANCED WARNING SIGNS AS SHOWN ON SHEET TMP-4. COVER ALL INSTALLED STATIONARY SIGNS EXCEPT THE W20-1 AND G20-2a SIGNS AT EACH APPROACH TO THE WORK ZONE.

STEP 2:
 USING ROADWAY STANDARD 1101.02, SHEET 1 OF 14, CLOSE ONE LANE OF TRAFFIC AND CONSTRUCT A TEMPORARY LEVEL SURFACE ON THE SHOULDER FOR THE PORTABLE SIGNAL. THE LEVEL SURFACE SHOULD BE CONSTRUCTED OF SUITABLE MATERIAL SUCH THAT THE PORTABLE SIGNAL WILL SET LEVEL FOR THE DURATION OF THE BRIDGE DECK REHABILITATION. CONSTRUCT BOTH LEVEL SURFACES AS SHOWN ON SHEET TMP 4. PLACE STOP BAR AND DOUBLE YELLOW PAVEMENT MARKING LINES AS SHOWN ON SHEET TMP-4.

STEP 3:
 USING ROADWAY STANDARD 1101.02, SHEET 1 OF 14, CLOSE ONE LANE OF TRAFFIC, INSTALL THE PORTABLE SIGNALS, STOP BAR, DRUMS ALONG THE CAUSWAY AND SKINNY DRUMS ACROSS THE BRIDGE FOR LANE CLOSURE AND UNCOVER STATIONARY WORK ZONE SIGNS. (SEE SHEET TMP-4) ACTIVATE PORTABLE SIGNALS AND REMOVE PORTABLE WORK ZONE SIGNS AND FLAGGERS SHOWN IN ROADWAY STANDARD DRAWING 1101.02.

STEP 4:
 WORKING INSIDE THE LANE CLOSURE, REHABILITATE THE FIRST HALF OF THE BRIDGE DECK AND CAUSEWAY SLOPE REPAIR ACCORDING TO THE PLANS. SEE SECTION A-A ON SHEET TMP-4

AREA 1 PHASE II

STEP 1:
 PLACE THE PORTABLE SIGNALS ON "RED" RESET THE DRUMS AND SKINNY DRUMS TO CLOSE THE OPPOSITE LANE ON THE BRIDGE AND CAUSEWAY AS SHOWN ON SHEET TMP-5. RESUME SIGNAL PHASING FOR PORTABLE SIGNALS AND PLACE TRAFFIC ON THE NEWLY REHABILITATED LANE ACROSS THE BRIDGE. (SEE SHEET TMP-5)

STEP 2
 WORKING INSIDE THE LANE CLOSURE, REHABILITATE THE SECOND HALF OF THE BRIDGE DECK AND COMPLETE SLOPE WORK ON CAUSEWAY ACCORDING TO THE PLANS. SEE SECTION B-B ON SHEET TMP-5.

STEP 3
 UPON COMPLETION OF THE BRIDGE DECK REHABILITATION AND CAUSWAY SLOPE REPAIR, USE ROADWAY STANDARD DRAWING 1101.02 SHEET 1 OF 14 TO REMOVE THE PORTABLE SIGNALS, STOP BARS, BOTH LEVEL SURFACES THAT WERE CONSTRUCTED FOR THE PORTABLE SIGNALS, DRUMS AND SKINNY DRUMS ACROSS THE BRIDGE AND CAUSEWAY. REMOVE OR COVER STATIONARY SIGNS R10-6, W3-3, AND W20-4. PLACE TEMPORARY PAVEMENT MARKINGS ACROSS THE BRIDGE AS SHOWN ON SHEET TCP-5.

STEP 4:
 REMOVE WORK ZONE ADVANCE WARNING SIGNS AND ANY OTHER REMAINING TEMPORARY TRAFFIC CONTROL DEVICES. OPEN NC 903 TRAFFIC TO THE PROPOSED TWO-LANE TWO-WAY TRAFFIC PATTERN.

THE WORK OF AREA 2 (PAINTING STRUCTURAL STEEL AND CONCRETE REPAIR OF THE SUBSTRUCTURE) IS SEPARATE FROM AREA 1 (THE BRIDGE DECK REHABILITATION AND CAUSEWAY SLOPE REPAIR) AND CAN BE PERFORMED SIMULTANEOUSLY AND / OR INDEPENDENTLY FROM AREA 1 FROM THE WATER.

AREA 2 PHASE 1

STEP 1:
 USING SHEET TMP-2, PLACE SIGNS WITH ATTACHED FLASHING AMBER LIGHTS AND BUOYS TO CLOSE BRIDGE SPAN(S) TO MARINE / RECREATIONAL WATER TRAFFIC FOR REHABILITATION OF STRUCTURE STEEL AND CONCRETE REPAIR OF SUPERSTRUCTURE. FIXED STRUCTURES SUCH AS WORK PLATFORMS OR BARGES MUST BE LIT AT NIGHT.

CONTRACTOR SHALL MAINTAIN A MINIMUM OF 2 ADJACENT BRIDGE SPANS FOR MARINE AND RECREATIONAL NAVIGATION AT ALL TIMES. SEE SHEET TMP-2.

NOTE: IF WORK REQUIRES A TEMPORARY STAGING AREA FROM THE BRIDGE DECK, USE ROADWAY STANDARD DRAWING 1102.02 SHEET 1 OF 14 TO PROVIDE TEMPORARY LANE CLOSURE. ALSO SEE GENERAL NOTE "A" FOR LANE CLOSURES RESTRICTIONS AND SEE INTERMEDIATE CONTRACT TIMES FOR LIQUIDATED DAMAGES

STEP 2:
 USING SHEET TMP-2, RESET SIGNS WITH ATTACHED FLASHING AMBER LIGHTS AND BUOYS TO CLOSE ANOTHER BRIDGE SPAN(S) TO MARINE / RECREATIONAL WATER TRAFFIC FOR REHABILITATION OF STRUCTURE STEEL AND CONCRETE REPAIR OF SUPERSTRUCTURE. FIXED STRUCTURES SUCH AS WORK PLATFORMS OR BARGES MUST BE LIT AT NIGHT.

CONTRACTOR SHALL MAINTAIN A MINIMUM OF 2 ADJACENT BRIDGE SPANS FOR MARINE AND RECREATIONAL NAVIGATION AT ALL TIMES. SEE SHEET TMP-2.

NOTE: IF WORK REQUIRES A TEMPORARY STAGING AREA FROM THE BRIDGE DECK, USE ROADWAY STANDARD DRAWING 1102.02 SHEET 1 OF 14 TO PROVIDE TEMPORARY LANE CLOSURE. ALSO SEE GENERAL NOTE "A" FOR LANE CLOSURES RESTRICTIONS AND SEE INTERMEDIATE CONTRACT TIMES FOR LIQUIDATED DAMAGES

REPEAT STEP 2 UNTIL ALL SPANS ARE COMPLETE

STEP 3
 UPON COMPLETION OF PAINTING STRUCTURAL STEEL AND CONCRETE REPAIR OF STRUCTURAL STEEL, REMOVE BUOYS AND OPEN ALL SPANS TO MARINE / RECREATIONAL WATER TRAFFIC.

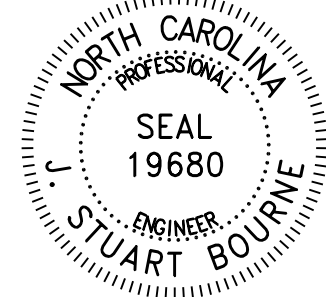
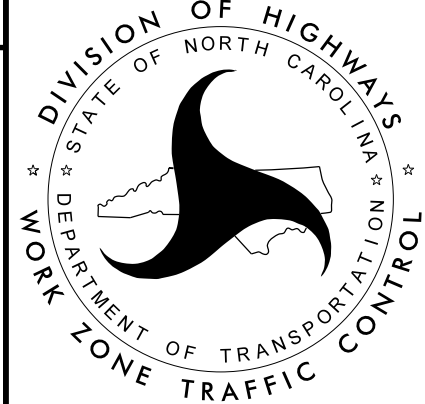
APPROVED: <u>J. Stuart Bourne</u> DATE: <u>2/8/2018</u> <small>20180208 12:56</small>			<h1 style="margin: 0;">PHASING</h1>
--	---	---	-------------------------------------

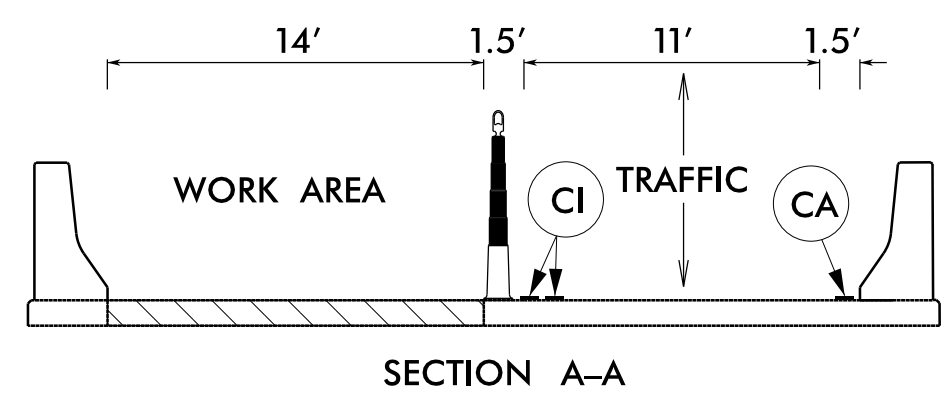
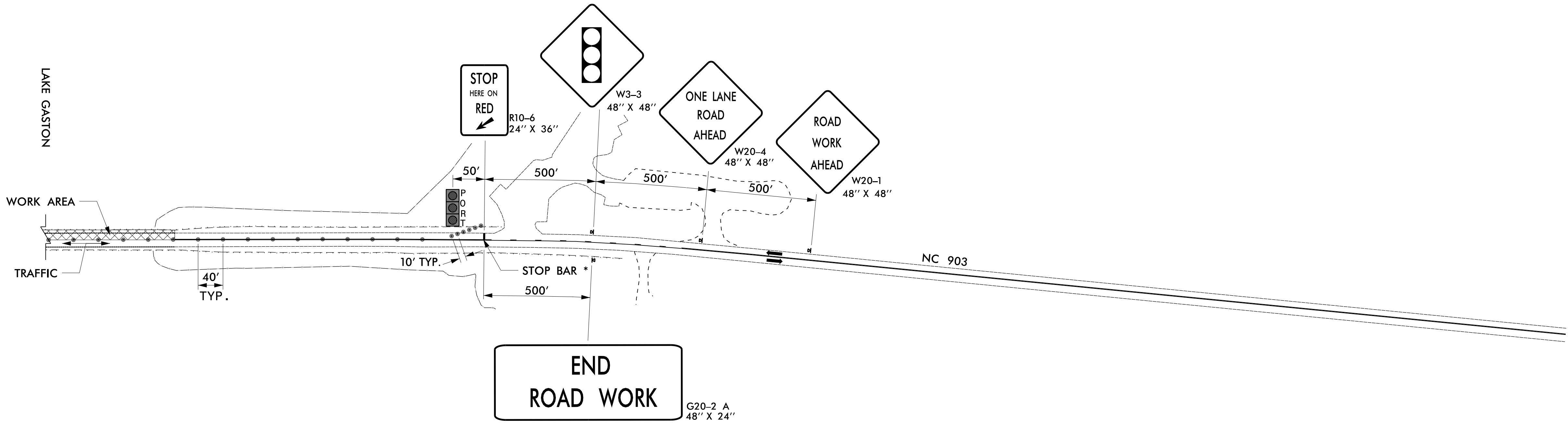
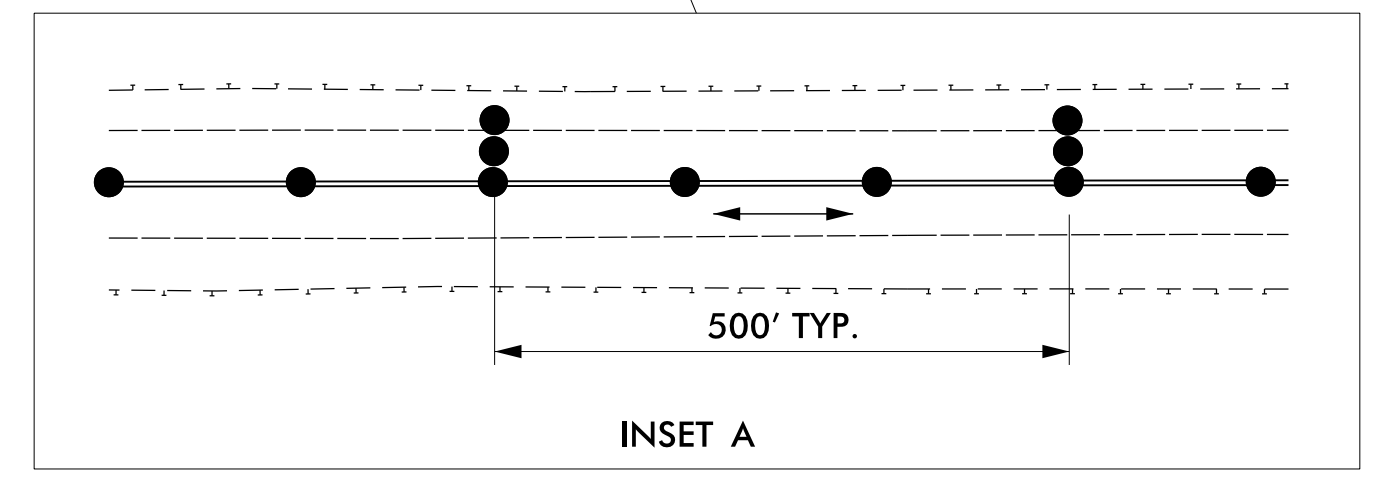
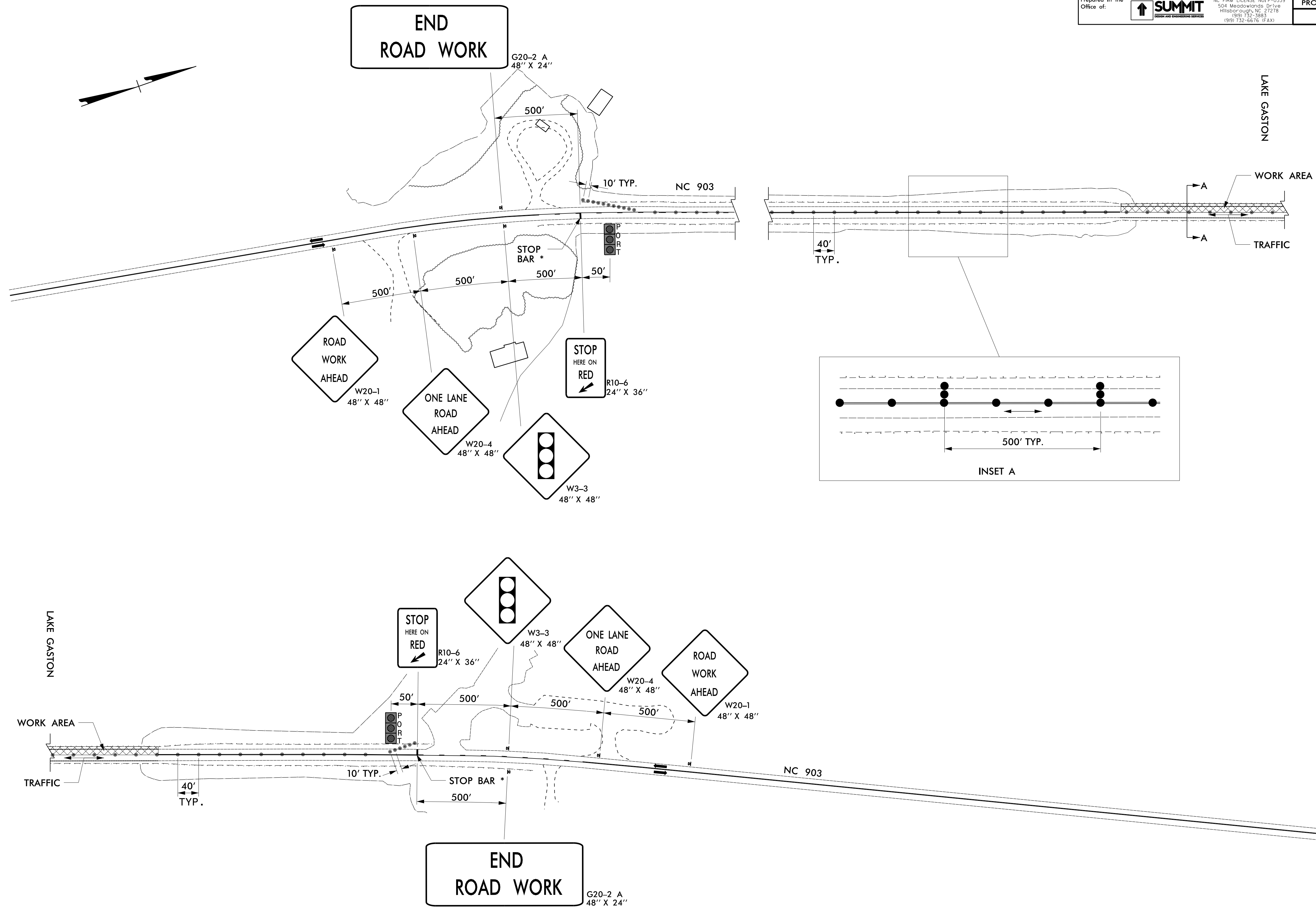

* SEE ROADWAY STANDARD DRAWING NUMBER 1101.02, SHEET 14 FOR PLACEMENT OF STOPBAR AND DOUBLE YELLOW CENTER LINE.

APPROVED <i>J. Stuart Bourne</i> <small>287656276F1248D</small> DATE: 2/2/2018 SEAL 		PHASE I
DOCUMENT NOT CONSIDERED FINAL UNLESS ALL SIGNATURES COMPLETED		

02-FEB-2018 14:04
 320039.LC.TMP.dgn
 spencer.merritt

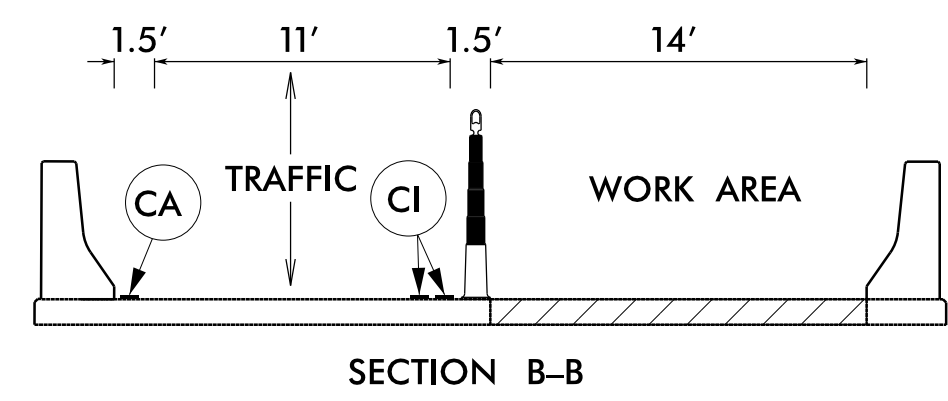
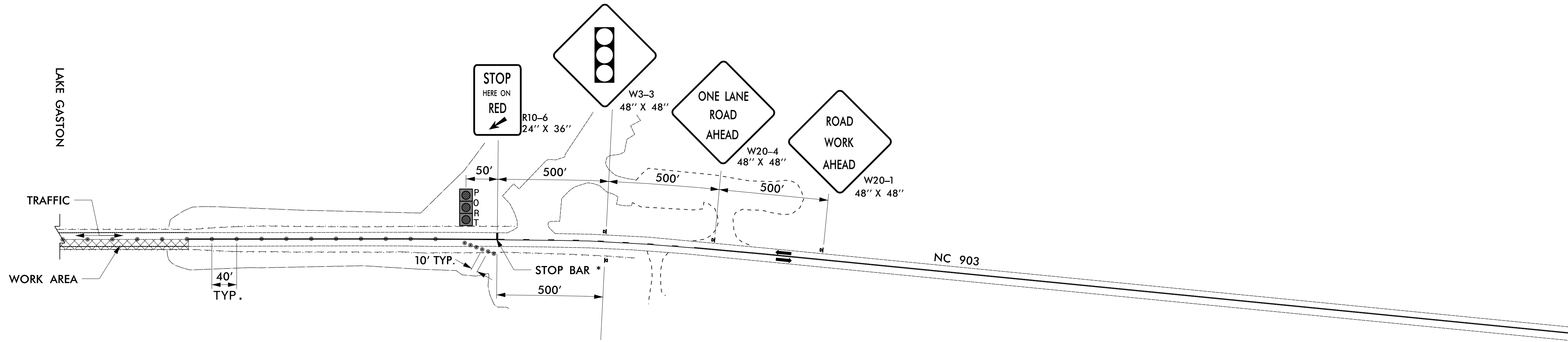
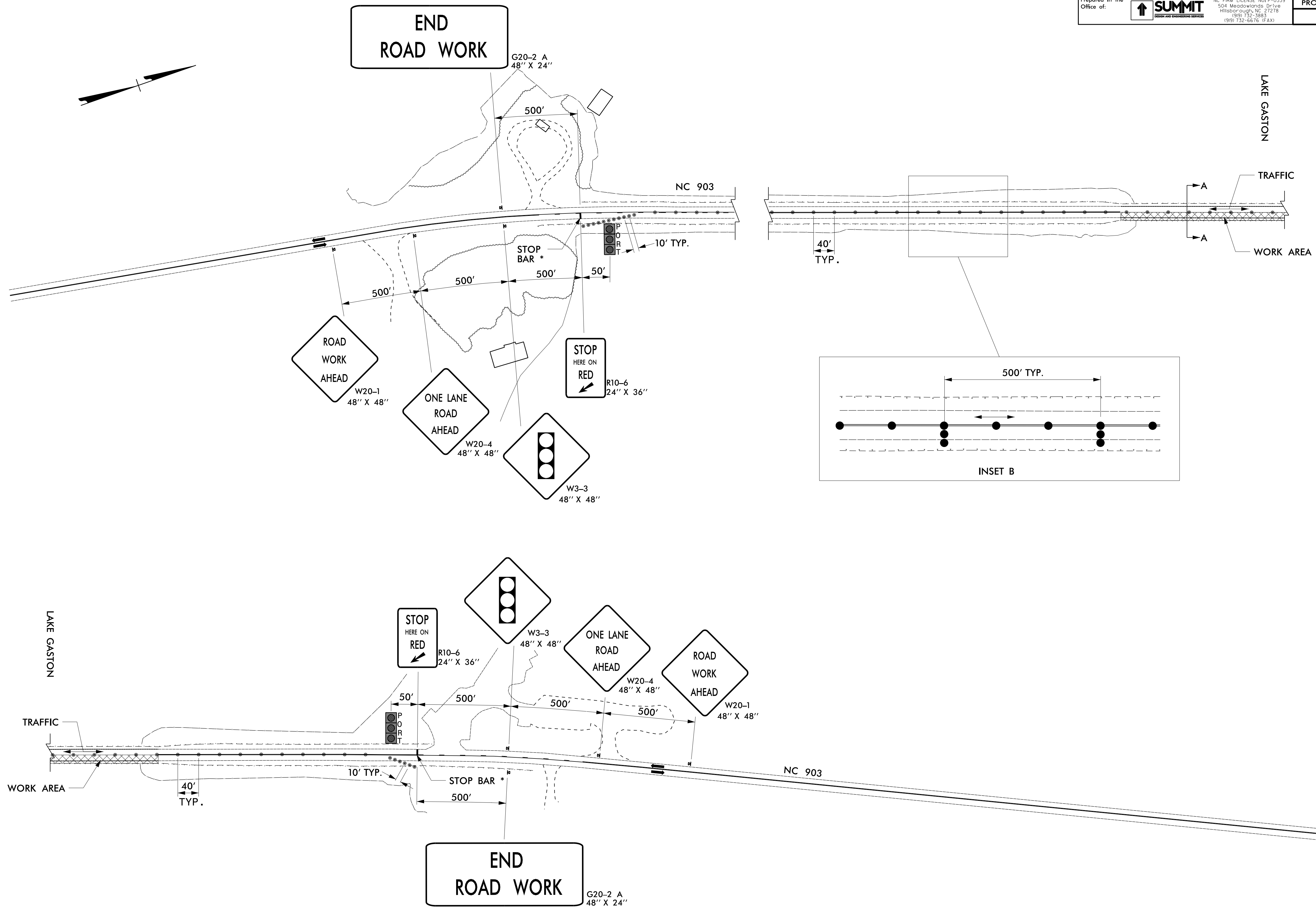

* SEE ROADWAY STANDARD DRAWING NUMBER 1101.02, SHEET 14 FOR PLACEMENT OF STOPBAR AND DOUBLE YELLOW CENTER LINE.

APPROVED: <u>J. Stuart Bourne</u> <small>267659678P12460</small>			<p>PHASE II</p>
DATE: 2/2/2018			
<p>DOCUMENT NOT CONSIDERED FINAL UNLESS ALL SIGNATURES COMPLETED</p>			

02-FEB-2018 14:04
320039.LC.TMP.5.dgn
spencer.merritt